





3

ON REQUEST

**SPECIAL TOOLS**

## SPECIAL END MILLS

Date: .....

Customer: .....

Attn: .....

Phone: .....

e-mail: .....

### Select type of tool

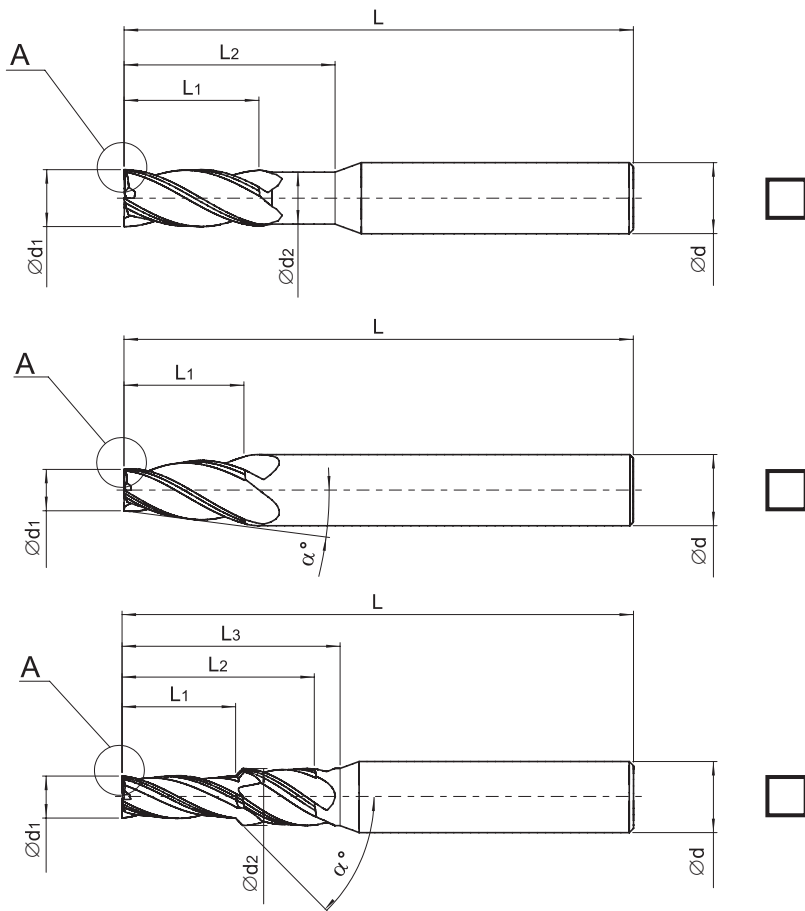

Ød	mm
Ød1	mm
Ød2	mm
L	mm
L1	mm
L2	mm
L3	mm
α	°
Ch	mm
αCh	°
Rcr	mm
R	mm
r	mm

### Select shape A

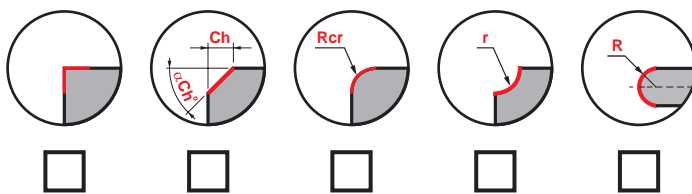

Material to be machined: .....

Internal cooling:  Yes  No

Number of flutes: .....

Helix angle: .....

Coating:  Yes  No

Quantity, pcs.: .....

Notes: .....

## STEP DRILLS

Date: .....  
 Customer: .....  
 Attn: .....  
 Phone: .....  
 e-mail: .....

Select type of tool

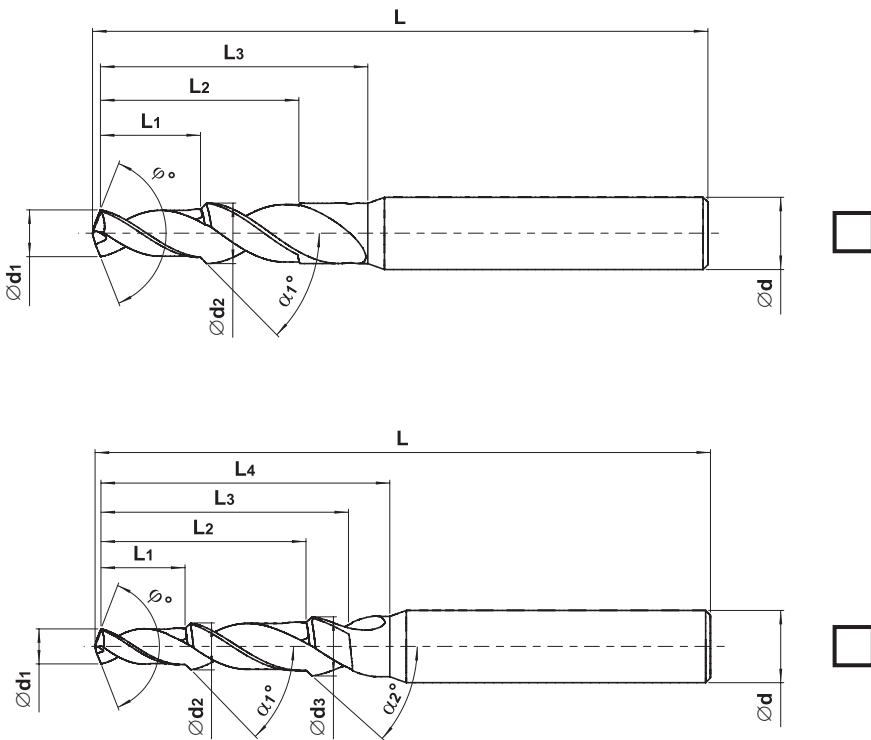

Ød	mm
Ød1	mm
Ød2	mm
Ød3	mm
L	mm
L1	mm
L2	mm
L3	mm
L4	mm
φ	°
α1	°
α2	°

Material to be machined: .....  
 Internal cooling:  Yes  No  
 Number of flutes: .....  
 Helix angle: .....  
 Coating:  Yes  No  
 Quantity, pcs.: .....  
 Notes: .....

## T-SLOT END MILLS

Date: .....  
 Customer: .....  
 Attn: .....  
 Phone: .....  
 e-mail: .....

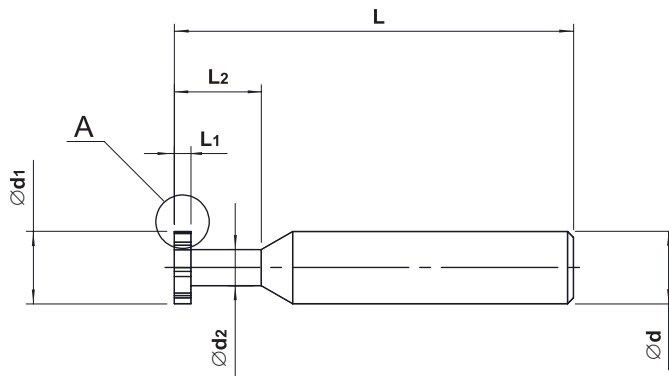

Ød	mm
Ød1	mm
Ød2	mm
L	mm
L1	mm
L2	mm
R	mm
Ch1	mm
Ch2	mm
αCh1	°
αCh2	°
Rcr1	mm
Rcr2	mm
R	mm

Select shape A

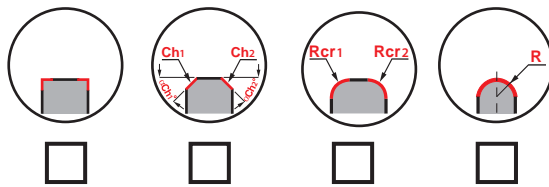

Material to be machined: .....  
 Internal cooling:  Yes  No  
 Number of flutes: .....  
 Helix angle: .....  
 Coating:  Yes  No  
 Quantity, pcs.: .....  
 Notes: .....

## REAMERS

Date: .....  
 Customer: .....  
 Attn: .....  
 Phone: .....  
 e-mail: .....

Select type of tool:

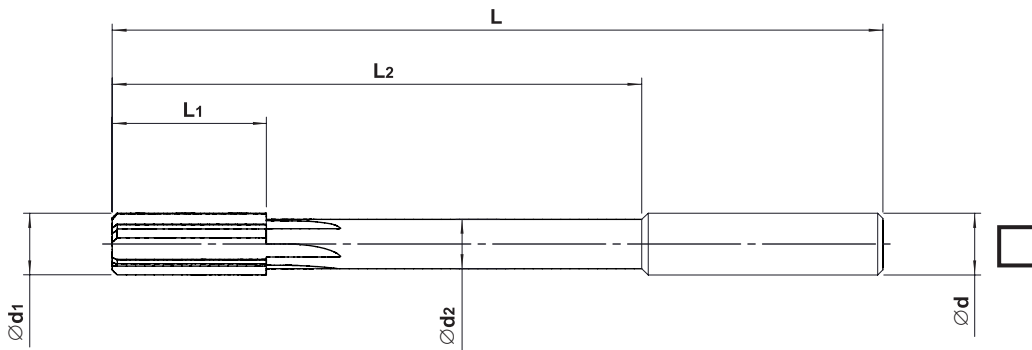

Ød	mm
Ød1	mm
Ød2	mm
L	mm
L1	mm
L2	mm

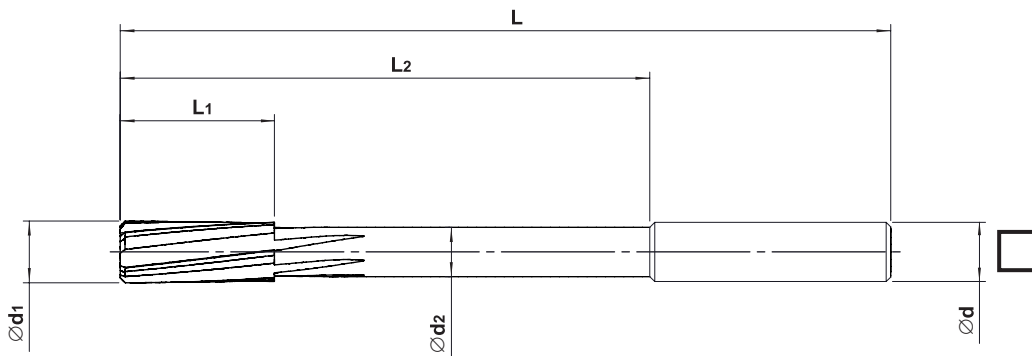

Material to be machined: .....  
 Internal cooling:  Yes  No  
 Number of flutes: .....  
 Helix angle: .....  
 Coating:  Yes  No  
 Quantity, pcs.: .....  
 Notes: .....  
 .....