

UMT 9654 Z=4

Сферические фрезы с короткой режущей частью и заниженной шейкой для обработки закаленных материалов
 Ball nose end mills with short cutting length and relieved neck for hardened materials

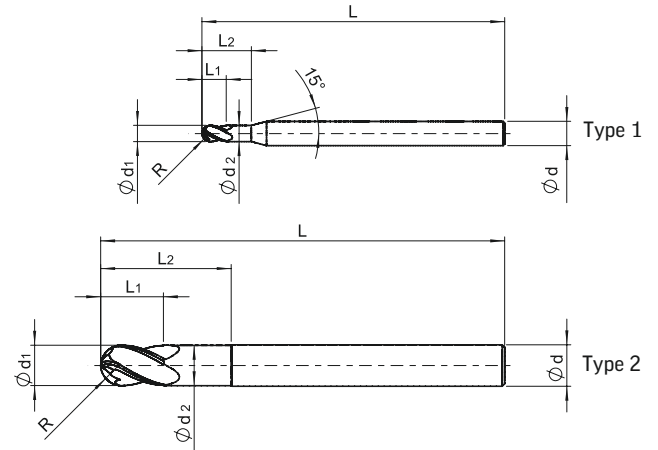
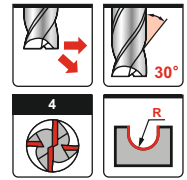

d1 (e8)	L1	L2	d2	d (h6)	L	R _{d1/2}	Stock	Type	ART No
3	5	10	2.9	6	75	1.5	●	1	9654030007500-1
4	6	13	3.9	6	75	2.0	●	1	9654040007500-1
5	8	16	4.9	6	75	2.5	●	1	9654050007500-1
6	9	20	5.8	6	75	3.0	●	2	9654060007500-1
8	12	25	7.8	8	100	4.0	●	2	9654080010000-1
10	15	32	9.7	10	100	5.0	●	2	9654100010000-1
12	18	38	11.7	12	100	6.0	●	2	9654120010000-1

**nano
TEC1**

● В наличии / In stock

Рекомендуемые режимы резания для фрез 9654
 Recommended cutting conditions for end mills 9654

Обрабатываемый материал Work material			Скорость резания Cutting speed V _c (m/min)	d1 - диаметр инструмента мм d1 - diameter in mm						
	Ap	Ae		Ø3	Ø4	Ø5	Ø6	Ø8	Ø10	Ø12
H Закаленные стали 45-55 HRC Hardened steel 45-55 HRC	<0.02d ₁	<0.03d ₁	nanoTEC1 200-250	0.04	0.048	0.05	0.054	0.057	0.057	0.059
Закаленные стали 55-60 HRC Hardened steel 55-60 HRC	<0.015d ₁	<0.02d ₁	100-150	0.038	0.045	0.046	0.052	0.056	0.056	0.058